



WARNING

USE CARE TO PREVENT INJURY.

COMPLY WITH THE FOLLOWING TO AVOID SERIOUS PERSONAL INJURY.

1. Guards must be provided on all power transmission and conveyor applications in accordance with provisions of ANSI/ASME B 15.1 1992 and ANSI/ASME B 20.1 1993 or other applicable standards. When revisions of these standards are published, the updated edition shall apply.
2. Always lock out power switch before installing, removing, lubricating or servicing a system that uses Cam Clutch products.
3. If the Cam Clutch is used for repeated starting and stopping, make sure the strength of the supports for the Cam Clutch are sufficient.
4. The capacity of your Cam Clutch may be effected by the accuracy of its set up, the amount of pressure exerted on it, wear on other parts in your system, or wear life of the Cam Clutch itself. Check the Cam Clutch at regular intervals and take any necessary safety precautions.
5. When connecting or disconnecting Cam Clutch products, eye protection is required. Wear safety glasses, protective clothing, gloves and safety shoes.



TSUBAKI EMERSON BACKSTOP CAM CLUTCHES BSEU & BS SERIES

*Sprag type one way clutch
High torque and longer life!!*



TSUBAKI EMERSON CO.

Group Companies:

U.S. TSUBAKI, INC.

301 E. Marquardt Drive
Wheeling, IL 60090
U.S.A.
Phone : 847-459-9500
Facsimile : 847-459-9515

TSUBAKI of CANADA LIMITED

1630 Drew Road
Mississauga, Ontario, L5S 1J6
Canada
Phone : 905-676-0400
Facsimile : 905-676-0904

TSUBAKI AUSTRALIA PTY. LTD.

Unit E. 95-101 Silverwater Road
Silverwater, N.S.W. 2128
Australia
Phone : 02-9648-5269
Facsimile : 02-9648-3115

TSUBAKIMOTO (THAILAND) CO., LTD.

Room No. C, T.W.Y. Office Center,
10th Floor, Serm-Mit Tower,
159 Soi Asoke, Sukhumvit Road,
North-Klongtoey Wattana, Bangkok 10110
Thailand
Phone : 66-2-261-9991/2
Facsimile : 66-2-261-9993

TSUBAKIMOTO SINGAPORE PTE. LTD.

25 Gul Lane
Jurong
Singapore 629419
Phone : 68610422/3/4
Facsimile : 68617035

TAIWAN TSUBAKIMOTO CO.

No. 7 Feng Sun Keng
Kuei Shan-Hsiang, Taoyuan-Hsien
Taiwan R.O.C.
Phone : 03-3293827/8/9
Facsimile : 03-3293065

TSUBAKI EMERSON CO.

TAIWAN BRANCH
5th F1., No. 2, Jen Ai Road, Sec.4, Taipei
Taiwan R.O.C.
Phone : 02-2325-9555
Facsimile : 02-2784-0022

1-1, Kotari-Kuresumi, Nagaokakyo,
Kyoto 617-0833, Japan

Internet:

<http://www.tsubaki-emerson.co.jp/english/>

Phone : (075) 957-3131
Facsimile : (075) 957-3122

TSUBAKIMOTO EUROPE B.V.

Belder 1, 4704 RK Roosendaal
The Netherlands
Phone : 0165-594800
Facsimile : 0165-549450

TSUBAKIMOTO U.K. LTD.

Osier Drive, Sherwood Park
Annesley, Nottingham, NG15 ODX
United Kingdom
Phone : 01623-688788
Facsimile : 01623-688789

TSUBAKIMOTO CHAIN CO.

Shanghai Representative Office
603 Unicom International Tower
547 Tianmu Xi Road, Shanghai,
China 200070
Phone : 021-6317-1662
Facsimile : 021-6317-0794

Distributed by:

BACKSTOP CAM CLUTCH

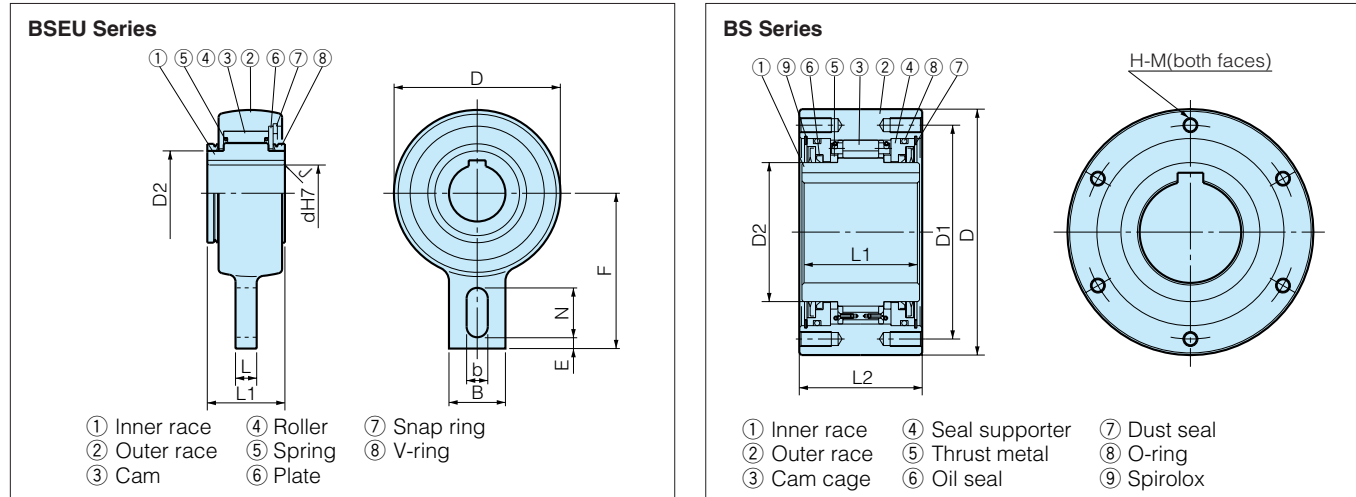

Dimensions and Capacity

Model	Stock Bore Size		Torque Capacity	Max. Overrun.	D	D2	L1	L2	L	B	F	b	N	E	J	D1	H-M Tapped Holes x Size x Pitch	Weight
	Dia	Keyway																
	H7		N·m	r/min	mm	mm	mm	mm	mm	mm	mm	mm	mm	mm	Chamfer	mm		kg
BSEU25-20	20	6 × 2.8	216	500	83	42	35	—	12	40	90	15	35	5	1.5	—	—	1.00
BSEU25-25	25	8 × 3.3	216	500	83	42	35	—	12	40	90	15	35	5	1.5	—	—	0.95
BSEU40-20	20	6 × 2.8	1,440	450	118	60	55	—	15	40	110	15	35	8	1.5	—	—	3.73
BSEU40-25	25	8 × 3.3	1,440	450	118	60	55	—	15	40	110	15	35	8	1.5	—	—	3.65
BSEU40-30	30	8 × 3.3	1,440	450	118	60	55	—	15	40	110	15	35	8	1.5	—	—	3.56
BSEU40-35	35	10 × 3.3	1,440	450	118	60	55	—	15	40	110	15	35	8	1.5	—	—	3.45
BSEU40-40	40	12 × 3.3	1,440	450	118	60	55	—	15	40	110	15	35	8	1.5	—	—	3.32
BSEU70-45	45	14 × 3.8	3,140	350	165	90	59	—	20	80	140	18	35	10	1.5	—	—	7.44
BSEU70-50	50	14 × 3.8	3,140	350	165	90	59	—	20	80	140	18	35	10	1.5	—	—	7.28
BSEU70-55	55	16 × 4.3	3,140	350	165	90	59	—	20	80	140	18	35	10	2.0	—	—	7.09
BSEU70-60	60	18 × 4.4	3,140	350	165	90	59	—	20	80	140	18	35	10	2.0	—	—	6.88
BSEU70-65	65	18 × 4.4	3,140	350	165	90	59	—	20	80	140	18	35	10	2.0	—	—	6.68
BSEU70-70	70	20 × 4.9	3,140	350	165	90	59	—	20	80	140	18	35	10	2.0	—	—	6.43
BSEU90-75	75	20 × 4.9	4,700	250	190	120	63	—	20	80	165	20	40	15	2.0	—	—	10.10
BSEU90-80	80	22 × 5.4	4,700	250	190	120	63	—	20	80	165	20	40	15	2.0	—	—	9.82
BSEU90-85	85	22 × 5.4	4,700	250	190	120	63	—	20	80	165	20	40	15	2.0	—	—	9.57
BSEU90-90	90	25 × 5.4	4,700	250	190	120	63	—	20	80	165	20	40	15	2.0	—	—	9.23
BS 95- 95	95	25 × 5.4	7,840	150	230	130	110	115	—	—	—	—	—	—	2.0	200	6 × M14 × P2.0	29.4
BS110-100	100	28 × 6.4	10,800	150	270	150	110	115	—	—	—	—	—	—	2.0	220	6 × M16 × P2.0	35.7
BS110-105	105	28 × 6.4	10,800	150	270	150	110	115	—	—	—	—	—	—	2.0	220	6 × M16 × P2.0	35.0
BS110-110	110	28 × 6.4	10,800	150	270	150	110	115	—	—	—	—	—	—	2.0	220	6 × M16 × P2.0	34.2
BS135	90 to 135	—	15,700	100	320	180	130	135	—	—	—	—	—	—	—	280	8 × M16 × P2.0	68.0
BS160	100 to 160	—	24,500	100	360	220	130	135	—	—	—	—	—	—	—	315	10 × M20 × P2.5	85.6
BS200	100 to 200	—	37,200	100	430	265	145	150	—	—	—	—	—	—	—	380	8 × M22 × P2.5	140.0
BS220	150 to 220	—	49,000	80	500	290	230	235	—	—	—	—	—	—	—	420	16 × M20 × P2.5	263.5
BS250	180 to 250	—	88,200	50	600	330	290	295	—	—	—	—	—	—	—	530	16 × M24 × P3.0	580.0
BS270	200 to 270	—	123,000	50	650	370	290	295	—	—	—	—	—	—	—	575	16 × M24 × P3.0	620.0
BS300	230 to 300	—	176,000	50	780	470	290	295	—	—	—	—	—	—	—	690	16 × M30 × P3.5	850.0
BS335	250 to 335	—	265,000	50	850	495	320	305	—	—	—	—	—	—	—	750	16 × M36 × P4.0	1,135
BS350	250 to 350	—	314,000	50	930	535	360	320	—	—	—	—	—	—	—	815	16 × M36 × P4.0	1,605
BS425	325 to 425	—	510,000	50	1,030	635	450	440	—	—	—	—	—	—	—	940	18 × M36 × P4.0	2,450
BS450	350 to 450	—	686,000	50	1,090	645	480	450	—	—	—	—	—	—	—	990	18 × M42 × P4.5	2,820

BACKSTOP CAM CLUTCH

Explanation 1

The Tsubaki Backstop Cam Clutch, a one-way clutch with the safest reverse rotation prevention qualities available, was manufactured mainly for installation on the low speed shaft of inclined conveyors or bucket elevators. The backstop cam clutch as well as all other Tsubaki Cam clutches is a one-way, sprag type clutch. Compared to other one-way clutches (ratchet or roller ramp clutch) similar in size, overheating during times when the motor is idling is significantly lower. This helps maintain superb lubrication qualities thereby improving the wear life of the clutch. Extended fatigue life is also obtainable due to the clutch's large torque capacity. Both the European style BSEU series, as well as the BS series cam clutch which boasts of thirty years of reputable performance since its introduction, can be used as reverse rotation prevention cam clutches for an array of conveyor sizes. Applicable shaft sizes range from $\phi 20 \sim \phi 450$ mm. Please refer to "TSUBAKI CAM CLUTCHES" (catalog no. 5111) for details on the BS series.

Installation and usage for BSEU series

- We recommend using a shaft tolerance of h7 or h8 for Cam Clutch installation.
- DIN6885.1 keyway is standard.
- Before installation, verify that the direction of rotation of the inner race of the Cam Clutch (shown by the arrow on the inner race) is the same as the direction of rotation of the conveyor.
- When inserting the Cam Clutch on the shaft, apply pressure only on the surface of the inner race with a soft hammer. Never strike the Cam Clutch with a steel hammer or apply unnecessary impact loads.
- Always use a parallel key for installation onto the shaft and then fix the Cam Clutch to the shaft with the end plate. Never use a tapered key. Allow for a clearance between the top of the clutch keyway and the top of the key for pressure ventilation. A pressure ventilation hole is provided on the keyway of the clutch's inner race.
- Use the frame or a pin to eliminate outer race rotation.
- Set a 0.5 mm degree clearance between the torque arm and the frame (torque arm stopper) or the long slit in the torque arm and the pin. If the torque arm is rigidly mounted, it will apply a load to the Cam Clutch which may eventually damage it.
- The Cam Clutch is pre-packed with low temperature grease before shipment and is ready for installation and operation. No lubrication maintenance is required. The ambient operational temperature range is -40° to 50°C . However, the maximum temperature should be determined depending on the number of shaft revolutions. Further, if the number of shaft revolutions is low, a higher ambient operational temperature range is allowable. Consult with Tsubaki for more details.

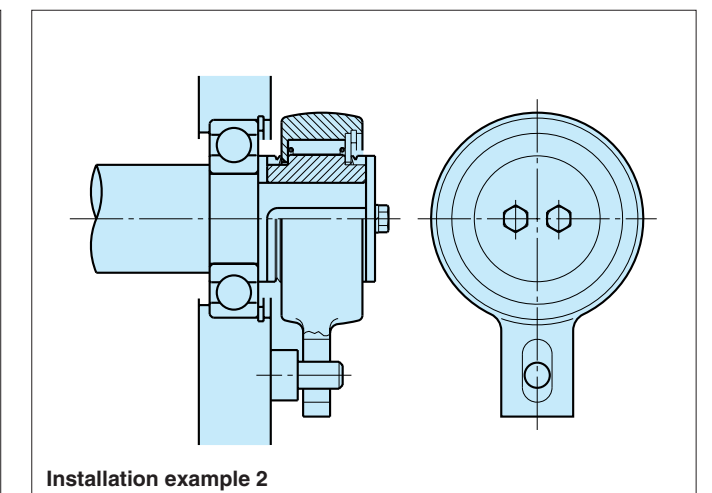
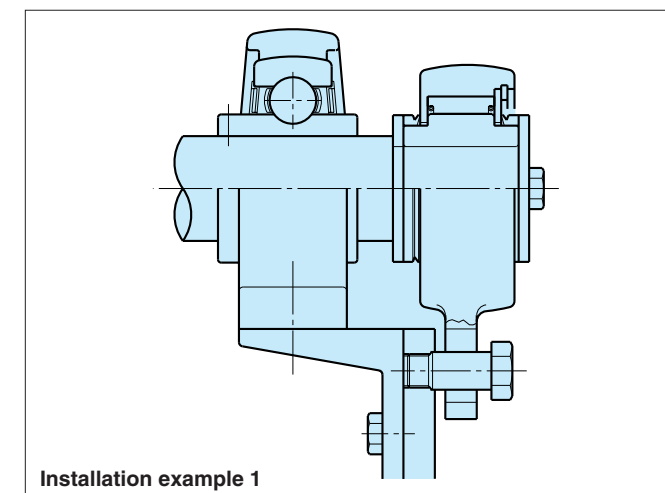

Explanation 2

Other Possible Applications:
 BSEU Series Cam Clutches may also be used for low frequency indexing applications. A maximum indexing frequency of no more than 50 cycles/min. and a safety ratio of 2.5 times higher than the working torque are required. Be sure that the stress applied to the torque arm functions at a right angle in relation to the shaft direction. If the stress that is applied to the torque arm is set diagonally, the inner parts of the clutch will entangle causing damage and drastically reduce the operational life of the Cam Clutch.